

NOTE: BREAK ALL CORNERS WITH 0.015" (.38 MM) RADIUS UNLESS OTHERWISE NOTED. STANDARD TOLERANCES TO APPLY UNLESS OTHERWISE SPECIFIED.

CUSTOMER CAN ART STD.	DIE No. EH05984	REV. No. 2
DESCRIPTION 2" SCHED 10 PIPE	CUSTOMER PART No.	PROPOSAL No. H-24358
	QUOTE No. 11-0460-1	

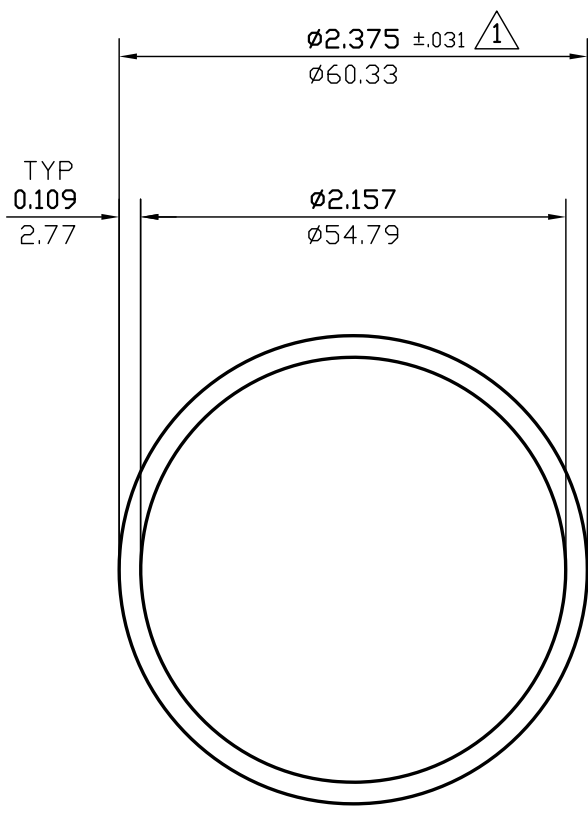

WALL THICKNESS **0.109 (2.77)** EXCEPT AS SHOWN

DATE	REV	DESCRIPTION	BY		
03/10/23	2	REMOVED ALLOY	JASON		
07/16/15	1	ADDED ±.031 TOLERANCE.	PAUL		
EST.AREA	0.776	IN. ²	EST.AREA	500.619	MM. ²
EST.WT.	0.916	LBS/FT.	EST.WT.	1.363	KG/M.
EST.PER.	14.238	IN.	EST.PER.	361.638	MM.
OUT PER.	7.461	IN.	OUT PER.	189.5	MM.
C.C.D.	2.375	IN.	C.C.D.	60.325	MM.
FINISH	M/F		ALLOY		
CKD BY	FACTOR 16	SCALE 1:1	DWN BY P.M.	DATE 05/19/2011	

CAN ART

85 PARKSHORE DRIVE
BRAMPTON, ONT L6T 5M1
TEL. NO. (905) 791-1464
FAX NO. (905) 791-9151
WEB: www.canart.com

ALUMINUM EXTRUSION INC.

THIS DRAWING IS NOT NECESSARILY A COPY OF YOUR ORIGINAL. PLEASE APPROVE DIMENSIONS AND TOLERANCES INDICATED. CAN ART ASSUMES NO RESPONSIBILITY EITHER TECHNICAL OR LEGAL FOR HAVING THIS SHAPE MADE. THE CUSTOMER AGREES TO FULLY PROTECT CAN ART ALUMINUM FROM CLAIMS OF OTHERS RESULTING FROM THIS SHAPE.

SIGNED: _____ DATE: _____